

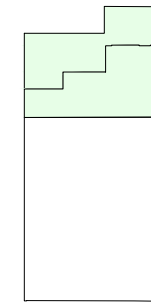

LOCATION DIAGRAM

PARRAMATTA ROAD



PARRAMATTA ROAD

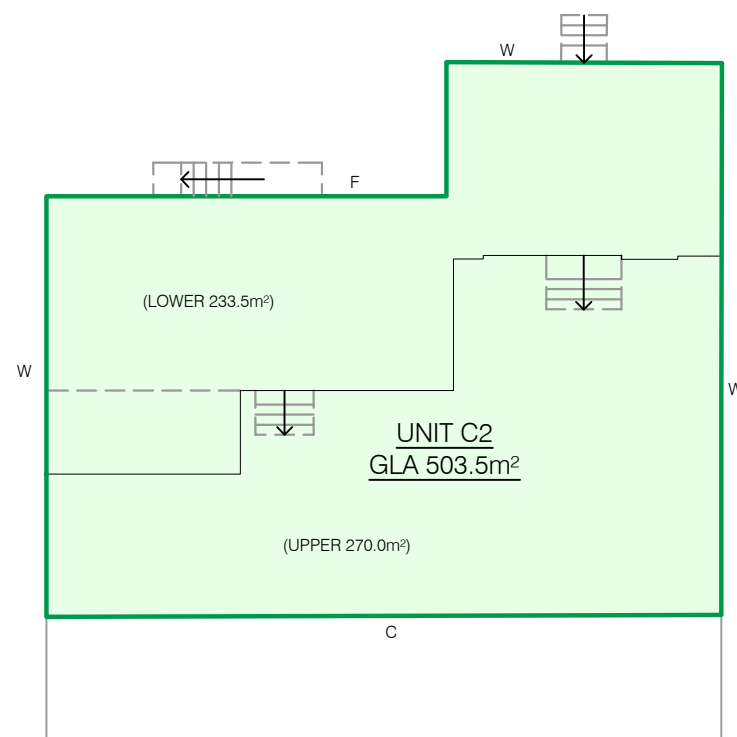

**GROUND LEVEL**

PARRAMATTA ROAD

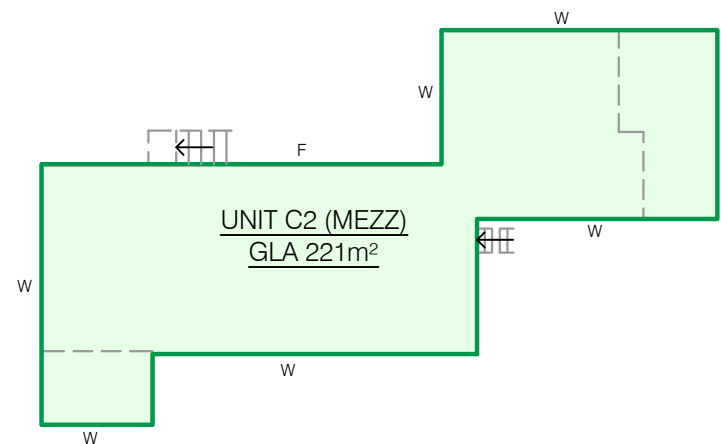

**MEZZANINE LEVEL**

LEGEND

- C TENANCY BOUNDARY IS CENTERLINE OF WALL
- G TENANCY BOUNDARY IS FACE OF GLASS
- W TENANCY BOUNDARY IS FACE OF WALL
- F TENANCY BOUNDARY IS FACE OF ALUMINIUM FRAME

SCHEDULE OF AREAS

UNIT C2	
-GROUND LEVEL (LOWER)	233.5m <sup>2</sup>
-GROUND LEVEL (UPPER)	270.0m <sup>2</sup>
-MEZZANINE LEVEL	221.0m <sup>2</sup>
<b>TOTAL:</b>	<b>724.5m<sup>2</sup></b>

NOTES

1. AREAS AND TENANCY BOUNDARIES HAVE BEEN DEDUCED IN ACCORDANCE WITH, AND UNDER INTERPRETATION OF THE 'PROPERTY COUNCIL OF AUSTRALIA' METHOD OF MEASUREMENT, REVISED EDITION MARCH 1997 (REPRINTED 2008) PART 2, GROSS LETTABLE AREA (G.L.A.)
2. ALL PARTIES USING THE AREAS EXPRESSED UPON THIS SKETCH SHOULD AGREE WITH THE BOUNDARY DELINEATIONS.

CLIENT:



TITLE:

**PLAN OF GROSS LETTABLE AREA (GLA)  
UNIT C2  
290 PARRAMATTA ROAD, AUBURN NSW**



**C.M.S. Surveyors Pty. Ltd.**  
A.C.N. 096 240 201  
PO Box 463 Dee Why NSW 2099  
2/99A South Creek Road, Dee Why NSW 2099  
Phone: (02) 9971 4802 Fax: (02) 9971 4822  
E-mail: info@cmssurveyors.com.au

SURVEYED DT	DRAWN CJR	CHECKED DT	APPROVED DT
19028A			
SURVEY INSTRUCTION 19028A		SCALE 1:300@A3	DATE OF SURVEY 14/12/2020
DRAWING NAME 19028A-GLA-C2-001			ISSUE 1
CAD FILE 19028A-C2-GLA-001.dwg			

1	FIRST ISSUE	18/12/2020
---	-------------	------------